

IN THE HIGH COURT OF KARNATAKA AT BENGALURU



DATED THIS THE 06TH DAY OF OCTOBER, 2023

BEFORE

THE HON'BLE MR. JUSTICE M. NAGAPRASANNA

CRIMINAL PETITION No.5952 OF 2023

C/W

CRIMINAL PETITION No.5741 OF 2023

CRIMINAL PETITION No.5788 OF 2023

IN CRIMINAL PETITION No.5952 OF 2023

BETWEEN:

- 1 . SRI SAMPANNA MUTALIK
S/O VIJAYA RAO MUTALIK
OCC: PRIVATE EMPLOYMENT
AGED ABOUT 55 YEARS
R/AT A1, 1ST CROSS,
OPP. 1ST BUS STOP,
BAPUJI VIDYANAGARA
DAVANAGERE
KARNATAKA – 577 005.
- 2 . SRI KARIBASAPPA G. M.,
S/O. MAHESHWARAPPA G. B.,
OCC: PRIVATE EMPLOYMENT
AGED ABOUT 57 YEARS
R/AT NO. 63, ARAKERE, HONNALI
DAVANAGERE
KARNATAKA – 577 217.

... PETITIONERS

(BY SRI H.S.CHANDRAMOULI, SENIOR COUNSEL AND
SRI PRATEEK CHANDRAMOULI, ADVOCATE)

AND:

- 1 . STATE OF KARNATAKA
BY THE ASSISTANT CONSERVATOR OF
FOREST, DAVANAGERE
REPRESENTED BY
STATE PUBLIC PROSECUTOR
HIGH COURT OF KARNATAKA
BENGALURU – 560 001.

- 2 . SRI S.K.DEVARAJ
THE RANGE FOREST OFFICER
DAVANAGERE RANGE
REP. BY STATE PUBLIC PROSECUTOR
HIGH COURT OF KARNATAKA
BENGALURU – 560 001.

... RESPONDENTS

(BY SRI JAGADEESHA B. N., ADDL. SPP. FOR R1 AND R2)

THIS CRIMINAL PETITION IS FILED UNDER SECTION 482 OF CR.P.C., PRAYING TO QUASHING THE ENTIRE PROCEEDINGS IN C.C.NO.2319/2023 (IN PCR NO.933/2022) REGISTERED AGAINST THE PETITIONER HEREIN ARRAIGNED AS ACCUSED NO.1 AND 2 FOR THE OFFENCE P/U/S.51 OF THE PROTECTION OF WILDLIFE ACT 1972 AND SEC. 465 AND 201 OF IPC PENDING ON THE FILE OF THE Ld.II ADDITIONAL CIVIL JUDGE AND JMFC DAVANAGERE.

IN CRIMINAL PETITION No.5741 OF 2023

BETWEEN:

SRI S.S.GANESH
S/O SRI S.SHIVASHANKARAPPA

OCC: INDUSTRIALIST
AGED ABOUT 62 YEARS
R/AT NO.2634/1, SHAMNUR ROAD
MCCB BLOCK, DAVANAGERE
KARNATAKA – 577 004.

... PETITIONER

(BY SRI H.S.CHANDRAMOULI, SENIOR COUNSEL AND
KUM. KEERTHANA NAGARAJ, ADVOCATE)

AND:

- 1 . STATE OF KARNATAKA
BY THE ASSISTANT CONSERVATOR OF
FOREST, DAVANAGERE
REP. BY STATE PUBLIC PROSECUTOR
HIGH COURT OF KARNATAKA
BENGALURU – 560 001.
- 2 . SRI S.K.DEVARAJ
THE RANGE FOREST OFFICER
DAVANAGERE RANGE
REP. BY STATE PUBLIC PROSECUTOR
HIGH COURT OF KARNATAKA
BENGALURU – 560 001.

... RESPONDENTS

(BY SRI JAGADEESHA B. N., ADDL. SPP. FOR R1 AND R2)

THIS CRIMINAL PETITION IS FILED UNDER SECTION 482 OF
CR.P.C., PRAYING TO QUASHING THE ENTIRE PROCEEDINGS IN
C.C.NO.2319/2023 (IN PCR NO.933/2022) REGISTERED AGAINST
THE PETITIONER HEREIN ARRAIGNED AS ACCUSED NO.7 FOR THE
OFFENCE P/U/S.51 OF THE PROTECTION OF WILDLIFE ACT 1972

AND SEC.465 AND 201 OF IPC PENDING ON THE FILE OF THE Ld.
ADDITIONAL CIVIL JUDGE AND JMFC DAVANAGERE.

IN CRIMINAL PETITION No.5788 OF 2023

BETWEEN:

MR. S.S.MALLIKARJUNA
S/O SHAMNUR SHIVASHANKARAPPA
AGED ABOUT 56 YEARS
R/AT NO.2636/1, "SHIVAPARVATHI"
MCC (B) BLOCK, DAVANAGERE
KARNATAKA – 570 004.

... PETITIONER

(BY SRI SANDESH CHOUTA, SENIOR COUNSEL REPR., AND
SMT. LEELA P.DEVADIGA, ADVOCATE)

AND:

- 1 . THE STATE OF KARNATAKA
BY DEPARTMENT OF FOREST
BY RANGE FOREST OFFICER
DAVANAGERE RANGE,
DAVANAGERE
REP. BY THE
STATE PUBLIC PROSECUTOR
HIGH COURT OF KARNATAKA
HIGH COURT BUILDING
BENGALURU – 560 001.
- 2 . SRI S.K.DEVARAJ
S/O NOT KNOWN
AGED ABOUT NOT KNOWN
RANGE FOREST OFFICER
DAVANAGERE RANGE

DAVANAGERE – 577 002.

... RESPONDENTS

(BY SRI JAGADEESHA B. N., ADDL. SPP. FOR R1 AND R2)

THIS CRIMINAL PETITION IS FILED UNDER SECTION 482 OF CR.P.C., PRAYING TO QUASH THE FINAL REPORT DATED 08.05.2023 PRODUCED AT ANNEXURE C IN C.C.NO.2319/2023 AND ALL FURTHER PROCEEDINGS IN C.C.NO.2319/2023 PURSUANT THERETO PENDING ON THE FILE OF THE 2nd ADDITIONAL CIVIL JUDGE AND JMFC JUDGE, DAVANAGERE FOR OFFENCE P/U/S.39,47,48,49,52,40(1),40(2),58 R/W SEC.51 OF WILDLIFE (PROTECTIONS) ACT 1972 AND SEC.465,201 OF IPC PRODUCED AT ANNEXURE A INsofar AS PETITIONER IS CONCERNED.

THESE CRIMINAL PETITIONS HAVING BEEN HEARD AND RESERVED FOR ORDERS ON 18.08.2023, COMING ON FOR PRONOUNCEMENT THIS DAY, THE COURT MADE THE FOLLOWING:-

ORDER

Batch of these petitions are preferred by the accused in a solitary crime. Different petitions are preferred by different accused. Criminal Petition No.5952 of 2023 is preferred by accused Nos.1 and 2; Criminal Petition No.5788 of 2023 is preferred by accused No.4 and Criminal Petition No.5741 of 2023 is preferred by accused No.7. They are all accused in Criminal Case No.2319 of

2023 pending before the II Additional Civil Judge and JMFC, Davanagere. Since facts that trigger registration of the crime are common, these petitions are taken up together and considered by this order.

2. Facts, in brief, adumbrated are as follows:

(I) Criminal Petition No.5952 of 2023:

(a) It is the case of the prosecution that it received credible information that an unknown person by name Senthil was standing in front of S.V. Complex, No.19, Bellary Road, Bengaluru and was found selling skin, antlers and teeth of wild animals. On such information being received, the sleuths of Hebbala Police Station with panchas apprehended Senthil and seized items mentioned *supra*. The jurisdictional police then registered a Forest Offence Crime ('FOC') in FOC No.1 of 2022 for offences punishable under Sections 39, 40, 48(a), 49(b), 50, 51, 55(b) of the Wild Life (Protection) Act, 1972 (hereinafter referred to as 'the Act' for short).

(b) Mr. Senthil was interrogated and thereafter, he was arrayed as accused No.1. He tenders his voluntary statement that he was rearing wild animals on instructions of the owner of Kalleshwar Rice Mills located in Anekonda, Davanagere District. Based on the said information, the Women Protection Wing of the CCB along with staff and panchas searched Kalleshwar Rice Mill and drew up a mahazar. The search was conducted on 21-12-2022. The product of the search was communicated to the Assistant Conservator of Forests, Davanagere for further action. The Range Forest Officer then files a written complaint before the Judicial Magistrate First Class, Davanagere under Section 200 of the Cr.P.C. against three persons *viz.*, Sampanna, G.M. Karibasaiah and Senthil. Sampanna and G.M. Karibasaiah are petitioners in the subject petition. The offences alleged in the said private complaint are the ones punishable under Sections 9, 39, 44, 48(a) and 51 of the Act. The crux of the complaint was that, on 21-12-2022 the complainant along with his staff members had visited the godown behind Samson Distilleries located in Anekonda Village, Davanagere Taluk wherein, the complainant found items specified, that were illegally kept in unlawful possession of the said accused. The

learned Magistrate on filing of the complaint, acting under Section 190(1)(a) of the Cr.P.C. takes cognizance of the offence under Section 51 of the Act. A direction was issued to investigate into the offence acting under Section 202(1) of the Cr.P.C., to the Assistant Conservator of Forests, Davanagere to conduct investigation and submit a report on or before 21.02.2023. The Investigating Officer then seeks all the documents pertaining to FOC No.1 of 2022, which was registered at Bangalore from the office of the CCB, which had conducted a search at Davanagere. After the said investigation, the Assistant Conservator of Forests registers a FIR under Rule 65(1) of the Karnataka Forest Manual for offences punishable under Sections 9, 40, 42, 42(a), 44, 48(a), 51 and 57 of the Act. Accused No.4 is added into these proceedings. Accused No.4 is the petitioner in the companion petition. On 29-04-2023, the Deputy Conservator of Forests seeks details of the investigation undertaken by the Investigating Officer along with statements of the accused recorded during investigation. As directed by the learned Magistrate, final report was filed before the Court on 08-05-2023. On 08-05-2023, on perusal of the final report, the learned Magistrate takes cognizance yet again against all the accused – accused Nos.1 to 7,

who were named in the final report for offences punishable under Section 51 of the Act. Apart from the said provision of the Act, the learned Magistrate opined that there was sufficient material to take cognizance for the offences punishable under Sections 465 and 201 of the IPC as well and registers a criminal case in C.C.No.2319 of 2023 against seven accused. The seven accused are as follows:
(i) Sampanna, (ii) G.M. Karibasappa, (iii) Senthil V,
(iv) S.S.Mallikarjun, (v) Kadu Junjappa @ Kadu Junja,
(vi) Anjinappa C and (vii) S.S. Ganesh.

(II) Criminal Petition No.5788 of 2023:

The petitioner in this petition is accused No.4 in C.C.No.2319 of 2023 and how this accused gets roped into the web of crime is already narrated hereinabove as the facts that led to arraigning of accused No.4 are similar to what is narrated *supra*.

(III) Criminal Petition No.5741 of 2023:

This petition is preferred by accused No.7 in C.C.No.2319 of 2023. This accused is roped into the web of crime, facts of which

are as narrated while narrating the facts in Criminal Petition No.5952 of 2023. Therefore, the subject criminal petitions are preferred by accused Nos. 1, 2, 4 and 7.

3. Heard learned senior counsel Sri Sandesh J. Chouta, appearing for the petitioner in Criminal Petition No.5788 of 2023; learned counsel Ms. Keerthana Nagaraj appearing for petitioners in Criminal Petition No.5952 of 2023 and Criminal Petition No.5741 of 2023 and the learned Additional State Public Prosecutor Sri B.N. Jagadeesha, representing the respondents in all the cases.

4. The learned senior counsel Sri Sandesh J. Chouta would contend that the procedure in which the investigation on the complaint was to be done under the Wildlife Offence Report No.1/2022 should have been completed therein as it is a complete code by itself. The registration of second FIR in FOC No.20 of 2022 in the teeth of the first FIR in FOC/WLOR No.1 of 2022 is clearly barred in law as there can be one crime registered for one offence. It is his submission that the entire procedure that is required for conduct of search and seizure are all thrown to the winds in the

cases at hand. The learned Magistrate has taken up proceedings completely contrary to law. He would, therefore, seek quashment of the entire proceedings on the aforesaid procedural aberrations. Apart from the aforesaid fact, he would also emphasise on the fact that entire proceedings are hit by mala fides and political vendetta as the charge sheet is filed on 08-05-2023 and elections to the Karnataka State Legislative Assembly were to take place on 10-05-2023 in which accused No.4 was to contest from Davanagere North constituency.

5. Ms. Keerthana Nagaraj, learned counsel for petitioners in the companion petitions taking this Court through the documents appended to the petitions would seek to contend that there are procedural violations in registration of the case and order of, taking cognizance. They are incurable illegalities. She would rely on the Wildlife Crime Investigation Handbook, which is followed as being a complete codified procedure for investigation of wildlife offences and would further submit that Section 202 of the Cr.P.C. under which power is exercised by the learned Magistrate should have been taken to its logical conclusion and there was no question of

reference being made under Section 156(3) of the Cr.P.C. It is her further contention that taking of dual cognizance is contrary to law. Likewise, hybrid investigation or trial is impermissible in law. Both the learned counsel appearing for the petitioners would place reliance upon the following judgments of the Apex Court and this Court : **(i) T.T. ANTHONY v. STATE OF KERALA¹; (ii) B.V. BYRE GOWDA v. NISAR AHMED²; (iii) KAPIL AGARWAL v. SANJAY SHARMA³; (iv) STATE OF HARYANA v. BHAJAN LAL⁴; (v) KAILASH VIJAYVARGIYA v. RAJLAKSHMI CHAUDHURI AND OTHERS⁵; (vi) BIRLA CORPORATION LIMITED v. ADVENTZ INVESTMENTS AND HOLDINGS LIMITED⁶; (vii) NATIONAL BANK OF OMAN v. BARAKARA ABDUL AZIZ⁷ and (viii) D. LAKSHMINARAYANA REDDY v. V. NARAYANA REDDY⁸.**

¹ (2001) 6 SCC 181

² CrI.P.No.3171 of 2018 decided on 20-09-2021

³ (2021) 5 SCC 524

⁴ 1992 Supp (1) SCC 335

⁵ 2023 SCC OnLine SC 569

⁶ (2019) 16 SCC 610

⁷ (2013) 2 SCC 488

⁸ AIR 1976 SC 1672

6. The learned Additional State Public Prosecutor Sri.B.N.Jagadeesha would refute the submissions to contend that a *prima facie* case is made out against the petitioners. None of the procedural violations that are projected by the petitioners would vitiate the proceedings. *Prima facie*, the petitioners have been found guilty of the offences and, therefore, further proceedings ought to be continued against these petitioners. The petitioners have committed serious offences which are punishable under the provisions of the Act and, therefore, there should be no interdiction or quashment of proceedings merely because there are some trivial procedural violations. He would seek dismissal of the petitions.

7. I have given my anxious consideration to the submissions made by the respective learned counsel and have perused the material on record.

8. The afore-narrated facts, dates and link in the chain of events are all a matter of record and, therefore, they would not require any reiteration. The offences alleged against these petitioners are the ones punishable under Sections 9, 39, 40, 48A,

49B, 50, 51, 55(b) and 57 of the Act. For offences punishable under the aforesaid provisions of the Act, if investigation has to be conducted, it has to be in terms of the Wildlife Crime Investigation Handbook. This is an admitted fact. Therefore, I deem it appropriate to notice the procedure stipulated for investigating the offences under the Act. Chapter-3 deals with registration of FOC which is akin to FIR, which also is sometimes named as Wildlife Offence Report ('WLOR'). Clauses 3.1 to 3.3 thereof read as follows:

*"3.1. In conventional crimes, investigation starts with registration of the case as First Information Report (FIR). Recovery of material evidence (stolen property, weapons, vehicles etc) takes place only after registration of the case. However, in wildlife crime cases, the seizure of the wildlife/wildlife article or apprehension of the accused/suspect may take place before registration of the case. In other words, in wildlife offences, investigation may start with lodging of a seizure / apprehension report or the offence report, in the jurisdictional court, by an authorised officer, who makes such seizure or arrest in different States this report is known by different names such as the Preliminary Offence Report (POR), H-2 Case, Offence Report. First Information Report (FIR), Seizure Intimation etc. However, it has been observed that some of the judicial officers who are new to wildlife crime cases doubt the legitimacy of such reports and insist on FIR/POR. There are some incidents where the jurisdictional magistrates refused to accept such reports as they are not on par with the First Information Report (FIR) filed by the police. In order to avoid such technical problems and to bring uniformity in practice, it is suggested that the first report submitted in the jurisdictional court in wildlife crime cases may be named as **Wildlife Offence***

Report (WLOR). *The Wildlife Offence Report should be prepared under Section 50(4) of the Wild Life (Protection) Act, 1972. A standard format for Wildlife Offence Report is given at **Annexure-III**.*

3.2 Check list for preparing Wildlife Offence Report (WLOR):

- (i) Every WLOR should be assigned a serial number maintained year wise eg: WLOR No. 1/2012 of _____, dated _____, Forest Range, Division/TRs)**
- (ii) Date and time of receipt of information at the Forest Range or detection of the offence should be mentioned in the WLOR.**
- (ii) WLOR should be prepared only on the standard format.**
- (iv) All columns in the WLOR should be duly filled.**
- (v) Correct Sections of law should be applied.**
- (vi) Address, present and permanent, parentage, age, sex etc of all the known accused/ suspects are to be mentioned in the WLOR.**
- (vii) If the accused/suspects are not known, the same should be mentioned in the WLOR.**
- (vii) In case of involvement of unknown accused, the words "and other unknown accused" should be mentioned after the list of the known accused.**
- (ix) Information part of the WLOR should be in simple language and without any ambiguity. It should provide sufficient grounds for proceeding against the accused**
- (x) Details of the wildlife involved, both common name and scientific name, Schedule under**

which the animal is listed in the WL (Protection) Act, quantum of punishment for the offence etc., should be incorporated in the information part.

(xi) Name and rank of the Investigating Officer, officer who made the seizure and the officer who wrote the WLOR should be mentioned in the WLOR

(xii) Delay in lodging of the WLOR should be avoided. In exceptional circumstances, if delay occurs, reasons for the same should be explained in the WLOR.

(xiii) Copy of the WLOR should be sent to the immediate supervisory officer and CWLW or officer authorised by him, without delay. This is needed so that immediate supervisory officer is aware of the commission of the offence under his jurisdiction and also enables him to advise/monitor the progress in its investigation.

3.3. Registration of FIR and investigation of offences under the Wild Life (Protection) Act, 1972, by police officer - Violations of the provisions of the Act are not specified as cognizable offence, therefore, police officers are often unwilling to lodge FIR and investigate offences reported under the provisions of the Act. It is clarified that under Part-II of Schedule-1 of the Criminal Procedure Code, 1973, offences against other laws, if punishable with imprisonment for 3 years and upwards are classified as cognizable. Most of the offences under the Act are punishable with imprisonment for 3 or more years. Therefore, an Officer In charge of a Police Station is bound to lodge an FIR and investigate the case like any other cognizable offence. However, courts shall take cognizance of any offence against the Act only on the complaint submitted by any person specified under Section 55 of the Act. Therefore, if Police officers in the State concerned are not authorized to file complaints under Section 55 of the Act, the Police report is to be submitted in the Court as complaint through an authorized forest officer. Once a

complaint is filed in court, no further investigation will be conducted without the direction of the Court Further, there is no provision for filing supplementary complaint once a complaint is filed. Therefore, any subsequent discovery, seizure, arrest etc. will be treated as fresh case and separate complaint filed in the Court."

(Emphasis supplied)

Chapter-6 deals with investigation and complaint. Clauses 6.1, 6.4, 6.5, 6.45, 6.47, 6.51, 6.52, 6.54 and 6.55 are germane to be noticed and they read as follows:

"6.1 The word investigation has been defined in Section 2(h) of the Criminal Procedure Code 1973 as;

"Investigation includes all the proceedings under this Code (Criminal Procedure Code) for the collection of evidence, conducted by a police officer or by any person (other than a Magistrate) who is authorised by a Magistrate in this behalf". A criminal investigation is a patient, step by step process of discovering collecting, preparing, identifying and presenting evidence within the legal frame work.

6.4. As per Section 50 of the Wild Life (Protection) Act, 1972, the Director of Wildlife Preservation or any other officer authorised by him in this behalf or the Chief Wildlife Warden or the authorised officer or any Forest Officer or any Police Officer not below the rank of Sub Inspector are empowered to enter into any place where the wildlife materials are suspected to be kept, conduct search for such wildlife materials and seize the same, arrest and detain the accused or the suspect. It is to be understood that all the actions together constitute investigation within the legal frame work of the Wild Life (Protection) Act, 1972.

6.5. In a typical case of wildlife crime, the investigating officer should plan investigation in the following manner:

- (i) Investigation at the scene of crime/scene of occurrence/Post Mortem of Carcass*
- (ii) Interrogation of the accused(s)/suspect(s)*
- (iii) Examination of the witness (es)*
- iv) Collection of documentary evidence(s)/samples for expert opinion.*
- (v) Collection of scientific/forensic evidence/digital evidence(s)*
- (vi) Collection and analysis of the evidence(s)*
- (vii) Filing complaint u/s 55 of the Wild Life (Protection) Act, 1972.*

6.45. Competence of an officer to file the complaint under section 55 of Wild Life (Protection) Act, 1972, is a matter of prime importance. The complaint has to be filed primarily by the Director of Wildlife Preservation or by any officer authorised by the Central Government or by the Chief Wildlife Warden or by any other officer authorised by the State Government. Therefore, before filing the complaint, the officer filing the complaint should ensure that he is authorised to file the complaint as envisaged under section 55 of the Act.

6.47. The complaint filed under section 55 of the Act, is to be treated as a complaint filed by public servant acting or purporting to act in the discharge of his official duties as mentioned in section 200(a) of Code of Criminal Procedure (Cr.P.C).

6.51. Statements of all the witnesses, including the official witnesses, recorded u/s 50(8) of the Act, as per the list of witnesses, confessional statements of the accused and statements recorded by the Magistrate u/s 164 Cr.P.C, if any, should be filed along with the complaint.

6.52 All documents in original or certified copy, as per the list of documents enclosed, should be submitted along with the Complaint. A comprehensive list of documents which are to be compulsorily submitted along with the Complaint is given below:

- (i) Copy of the Government notification empowering the authorised officer to file complaint u/s 55 of the Act.
- (ii) Notification under Section 50 of the Act empowering the officers to conduct search, arrest and investigation.
- (iii) Sketch of the scene of crime/scene of occurrence and Crime Scene Inspection Memo.
- (iv) Where the scene of crime/scene of occurrence is a protected area like National Park, Sanctuary or a Tiger Reserve, copy of the Government Notification declaring the area as a National Park, Sanctuary or a Tiger Reserve.
- (v) In case of unnatural deaths or hunting of animals, the Post Mortem report obtained from the Government Veterinary Surgeon(s)/ Team of VSs.
- (vi) Reports of experts from Forensic Science Laboratory, Wildlife Institute of India, Zoological Survey of India, Botanical Survey of India etc.
- (vii) A sheet containing specimens of the seals used for sealing the materials seized.
- (viii) Copy of documents proving ownership of vehicles seized, house/shops etc from where the seizure was made.

- (ix) *In case of seizure of fire arms, certified copy of the Ballistic examination report.*
- (x) *In case of seizure of mobile phones, the Call Data Records (CDR), only if it is relevant to the case. If these are cited as evidence, a certificate under section 65 B of Indian Evidence Act should be obtained from service providers.*
- (xi) *Photographs of the seized material, scene of crime/scene of occurrence or videographs of the Post mortem etc on CDs.*
- (xii) *Copy of the WLOR.*
- (xiii) *All the other documents collected during the course of investigation which are relevant to the case in hand.*
- (xiv) *List of witnesses.*

6.54 Once a complaint is filed in court, there is no provision for further investigation or submission of supplementary complaints in the case.

6.55. A Flow Chart of the sequential steps to be followed by an Investigation Officer in wildlife crime investigation process is given at Annexure - XII."

(Emphasis supplied)

Chapter-6, in which the afore-quoted clauses would come, deals with investigation and complaint. Clause 6.5 (*supra*) deals with investigation into a wildlife crime and the manner of investigation is stipulated. Sub-clause (vii) thereof deals with complaints filed under Section 55 of the Act. Clause 6.45 deals with filing of

complaint under Section 55 of the Act by a competent Officer and who is competent is also depicted. A complaint filed under Section 55 of the Act is to be treated as a complaint filed by a public servant in the discharge of his official duties as obtaining under Section 200 (a) of the Cr.P.C. Clause 6.51 directs that statements of all witnesses should be recorded in terms of the procedure stipulated in clause 6.52. Clause 6.52 mandates that the complaint filed before the learned Magistrate should compulsorily contain certain documents, two of which are a copy of the WLOR and list of witnesses. Once the complaint is filed before the Court, there is no provision for further investigation or submission of supplementary complaint in a given case. Clause 6.55 depicts flow chart as obtaining in the annexures appended to the manual. The annexures i.e., Annexures XI and XII read as follows:

"ANNEXURE-XI

Complaint In A Wildlife Offence

(U/s 55 of Wild Life (Protection) Act 1972)

1	<i>Name of the Range Office/Division</i>	
2	<i>WLOR number and date</i>	
3	<i>Place and date of offence</i>	
4	<i>Sections of law</i>	
5	<i>Details of property seized</i>	
6	<i>Whose custody the seized properties are</i>	

	<i>lying, if submitted in the court Property Index number</i>	
7	<i>Live specimens, if any, seized and subsequently rehabilitated in its natural habitat as per the court order</i>	
8	<i>Details of perishable or hazardous material seized and subsequently destroyed as per the court order</i>	
9	<i>Details of firm arms, if any, seized and handed over to the Police for investigation and the police FIR number</i>	
10	<i>Whether samples were sent to wildlife Institute of India, Zoological Survey of India, Botanical Survey of India or any other scientific experts for opinion and the details of the opinion received</i>	
11	<i>Name, designation and office address of the officer who filed the Offence Report</i>	
12	<i>Name, designation and office address of the officer filing the Complaint</i>	
13	<i>Name and address of the accused against whom the Complaint is filed</i>	
(i)	<i>Accused in custody</i>	
(ii)	<i>Accused on bail</i>	
(iii)	<i>Accused not arrested/absconding</i>	
(iv)	<i>Accused who are habitual/ repeated offenders, details of previous cases</i>	
14	<i>Name and address of the witnesses and facts to be proved by the evidence of each witness</i>	
15	<i>List of documents, if any, submitted along with the complaint</i>	
16	<i>Nature of offences and facts of the case/allegation made against each accused</i>	

Prayer :

*Name & designation of the complainant
With office seal*

To
The Chief Judicial Magistrate/JMFC
(Address)

ANNEXURE-XII
Flow Chart on WI Crime Investigation Process

Wild Life (Protection) Act, 1972, was enacted to prevent, control and conserve biodiversity of the country. It extends to the whole of India excepts J & K

(A)

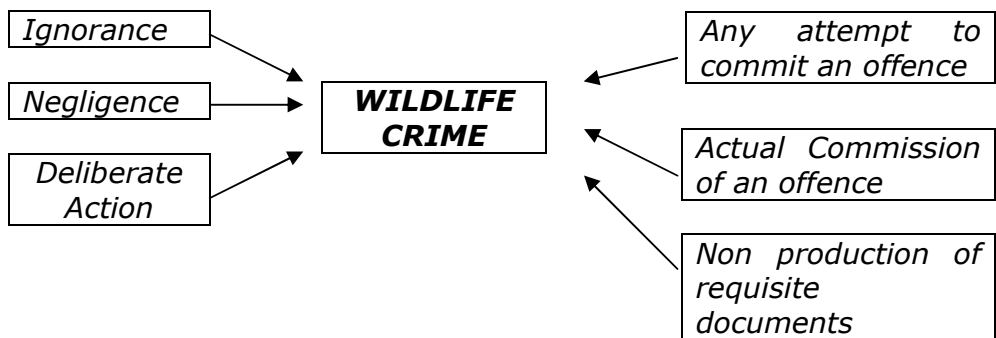

One or more offences under following Sections of WL(P) Act, 1972:
 I) 17A, 27, 29, 30, 31, 32, 33A and 35 - up to 3 years
 II) 9, 39, 44, 48A and 49B - 3-7 years

(B)

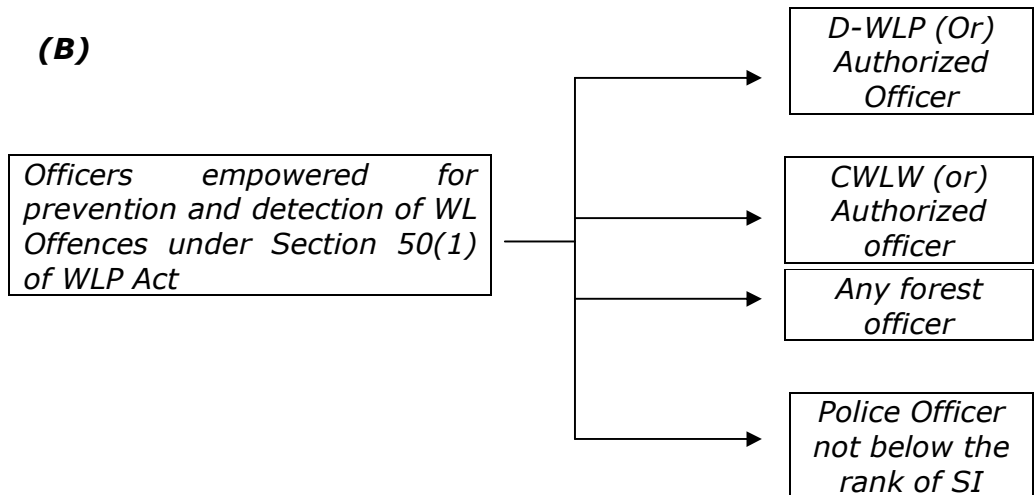

(C)

Person Arrested And Things Seized Are To Be Produced Before The Magistrate Under Intimation To The Chief Wildlife Warden Of The State Of Officer Authorized By Him Under Section 50(4) of the WLP Act

(D)

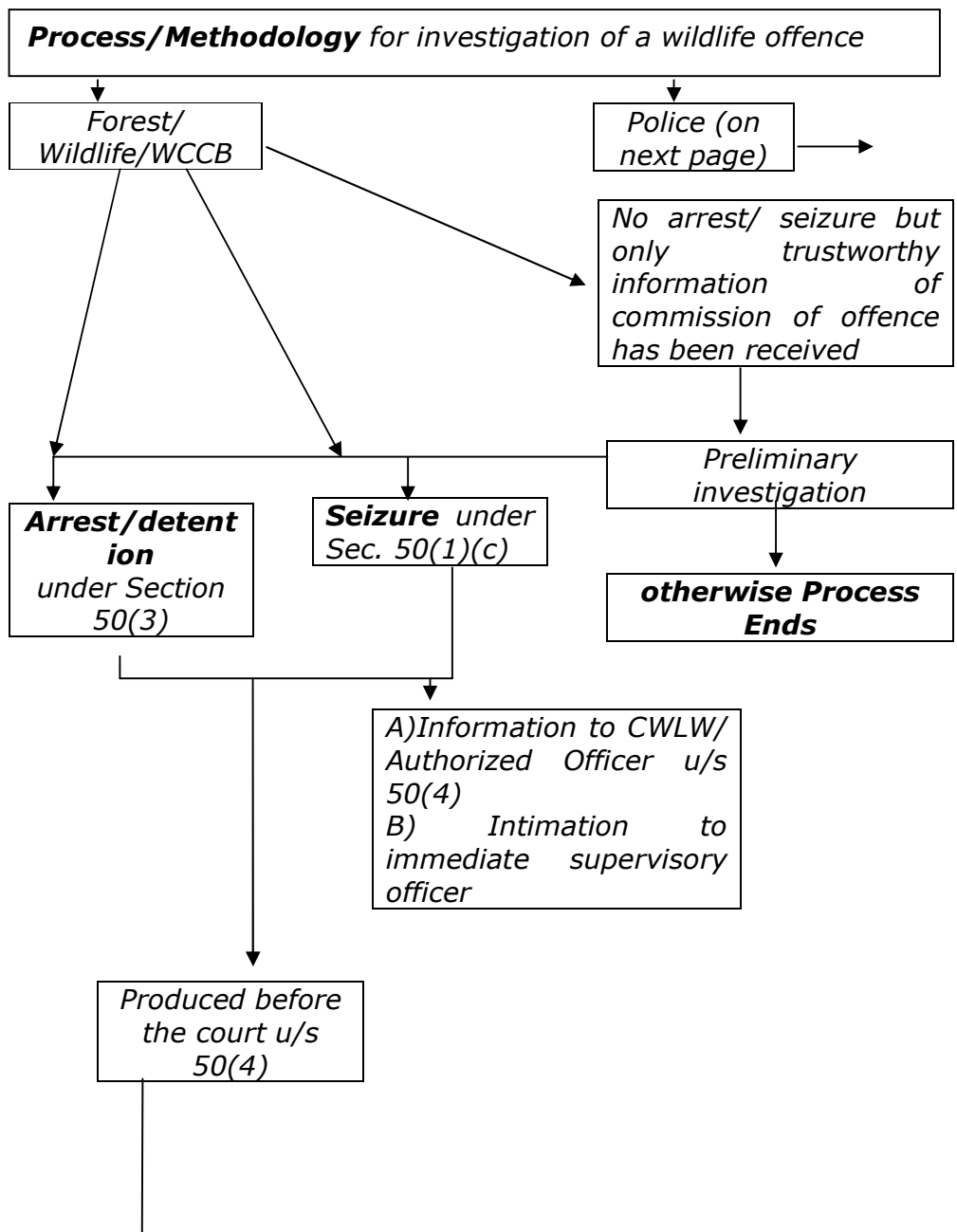

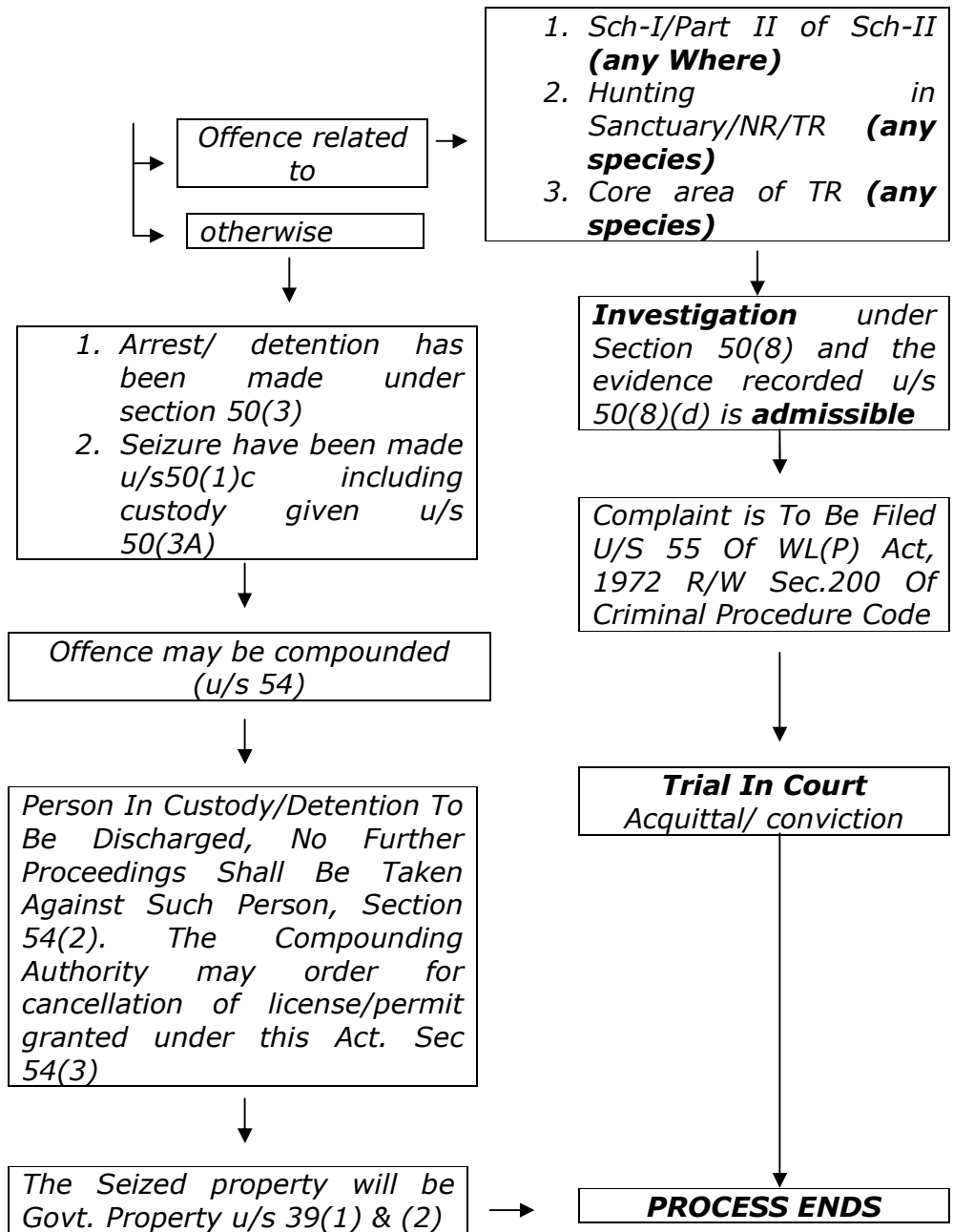

Offence related to

otherwise

- 1. Sch-I/Part II of Sch-II **(any Where)**
- 2. Hunting in Sanctuary/NR/TR **(any species)**
- 3. Core area of TR **(any species)**

- 1. Arrest/ detention has been made under section 50(3)
- 2. Seizure have been made u/s50(1)c including custody given u/s 50(3A)

Investigation under Section 50(8) and the evidence recorded u/s 50(8)(d) is **admissible**

Complaint is To Be Filed U/S 55 Of WL(P) Act, 1972 R/W Sec.200 Of Criminal Procedure Code

Offence may be compounded (u/s 54)

Trial In Court
Acquittal/ conviction

Person In Custody/Detention To Be Discharged, No Further Proceedings Shall Be Taken Against Such Person, Section 54(2). The Compounding Authority may order for cancellation of license/permit granted under this Act. Sec 54(3)

The Seized property will be Govt. Property u/s 39(1) & (2)

PROCESS ENDS

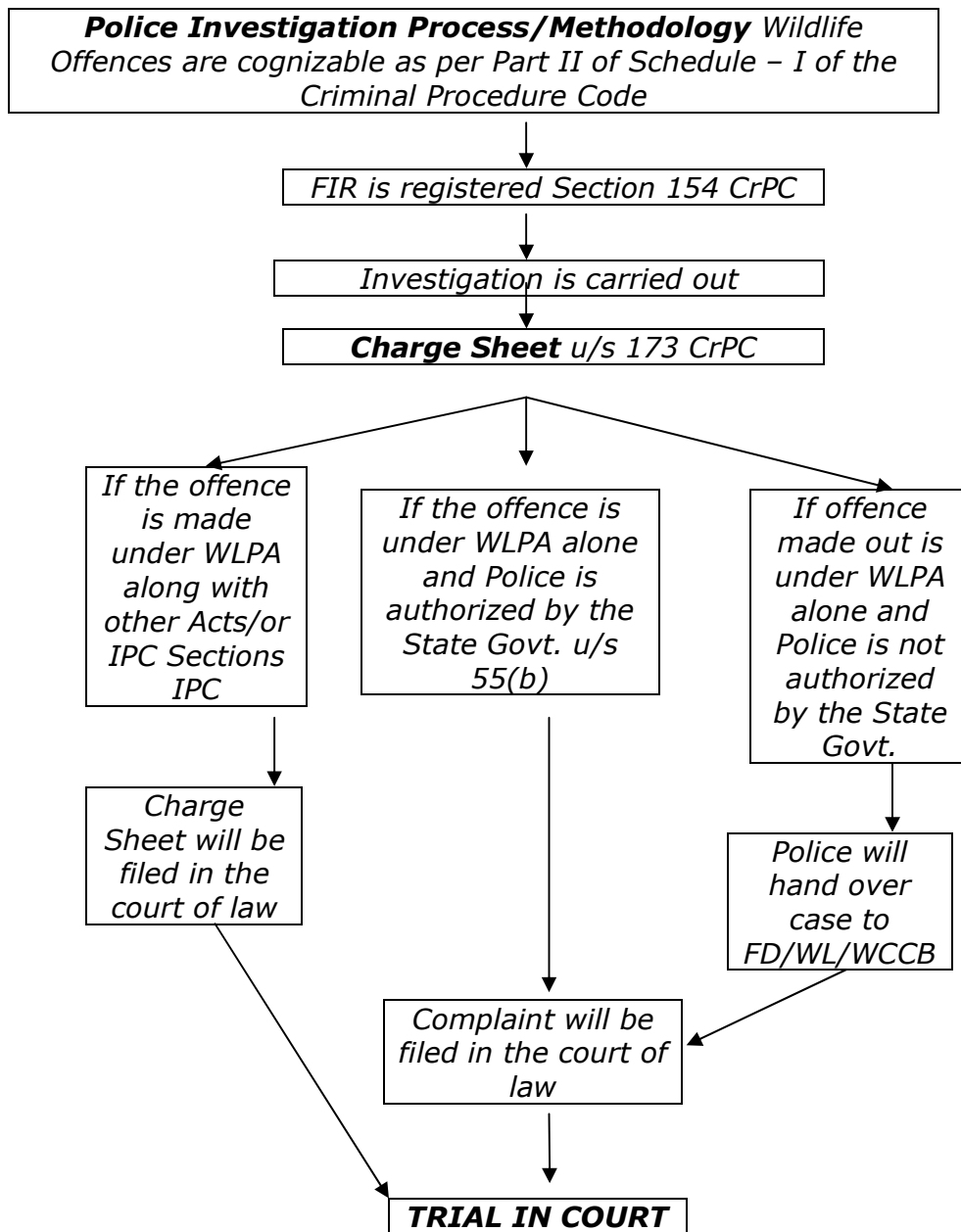

This is the frame work of the handbook which is to be followed in every case of wildlife offence. It is a complete code from registration of crime till investigation.

9. On the bedrock of what is quoted hereinabove, the procedure followed is what is required to be noticed. After conduct of search and seizure if the wildlife offence is detected, then the Forest Officer has to record all the details in the Wildlife Offence Register in terms of prescribed format and prepare a Wildlife Offence Report in terms of flow chart depicted hereinabove. This is given a complete go-bye. It is thereafter, the complaint would be preferred before the jurisdictional Magistrate under Section 200 of the Cr.P.C. This procedure is violated for it to become ***topsy-turvy***. What the Range Forest Officer would do is to register the FIR at the outset and later, file a complaint before the learned Magistrate both of which are on the same offence.

10. The duty of the learned Magistrate is to conduct an inquiry under Section 202 of the Cr.P.C. to find out whether at all the matter would require investigation by a criminal Court. There was no question of referring the matter under Section 156(3) of the Cr.P.C. to decide whether Section 204 Cr.P.C. should be followed or

otherwise. Sections 202 and 204 of the Cr.P.C. are completely violated in the case at hand.

11. On 08-05-2023 after the final report was placed before the learned Magistrate, the learned Magistrate takes cognizance of the offence under Section 190(1)(b) of the Cr.P.C. for the offences under Section 51 of the Act and Sections 465 and 201 of the IPC. This is the second cognizance taken by the learned Magistrate. What is the first is required to be noticed. When the complaint is registered by the Range Forest Officer on 21-12-2022 invoking Section 200 of the Cr.P.C. for the afore-quoted offences, the learned Magistrate takes cognizance and issues summons acting under Section 190(1)(a) of the Cr.P.C. Section 190 of the Cr.P.C. reads as follows:

"190. Cognizance of offences by Magistrates.—

(1) Subject to the provisions of this Chapter, any Magistrate of the first class, and any Magistrate of the second class specially empowered in this behalf under sub-section (2), may take cognizance of any offence—

- (a) upon receiving a complaint of facts which constitute such offence;*
- (b) upon a police report of such facts;*

(c) *upon information received from any person other than a police officer, or upon his own knowledge, that such offence has been committed.*

(2) *The Chief Judicial Magistrate may empower any Magistrate of the second class to take cognizance under sub-section (1) of such offences as are within his competence to inquire into or try."*

The learned Magistrate can take cognizance under both the provisions *i.e.*, Section 190(1)(a) or 190(1)(b)(c) of the Cr.P.C. One would be on the police report and the other would be on the product of the inquiry directed under Section 202 of the Cr.P.C. Both deal with taking of cognizance. Once having taken cognizance, it was clearly impermissible in law to have taken cognizance yet again on 08-05-2023 for the offence that had already been taken cognizance on 22-12-2022. Therefore, the procedure followed by the learned Magistrate is also ***topsy-turvy***.

12. As observed hereinabove, the offences under the Act would fall under the manual which is a complete code by itself. The Police by registering Criminal Case No.2319 of 2023 have envisaged a situation of hybrid trial for the same offence before one forum *i.e.*, the learned Magistrate. This is also impermissible in law as

there is marked difference between the enquiry to be conducted under Section 202 of the Cr.P.C. and the reference being made by the learned Magistrate for conduct of investigation under Section 156(3) of the Cr.P.C. The net result of all the aforesaid actions is multiple criminal proceedings being registered on the same offence which is clearly impermissible in law.

13. Reference being made to the judgment of the Apex Court in the case of **T.T.ANTHONY** (*supra*) and the order passed by this Court in the case of **B.V. BYRE GOWDA** (*supra*), which followed the judgment in the case of **T.T.ANTHONY** in the circumstances becomes apposite. The Apex Court in the case of **T.T. ANTHONY** has held as follows:

"20. *From the above discussion it follows that under the scheme of the provisions of Sections 154, 155, 156, 157, 162, 169, 170 and 173 CrPC only the earliest or the first information in regard to the commission of a cognizable offence satisfies the requirements of Section 154 CrPC. Thus there can be no second FIR and consequently there can be no fresh investigation on receipt of every subsequent information in respect of the same cognizable offence or the same occurrence or incident giving rise to one or more cognizable offences. On receipt of information about a cognizable offence or an incident giving rise to a cognizable offence or offences and on entering the FIR in the station house diary, the officer in charge of a police station has to investigate not merely the*

cognizable offence reported in the FIR but also other connected offences found to have been committed in the course of the same transaction or the same occurrence and file one or more reports as provided in Section 173 CrPC."

This Court in **B.V.Byre Gowda** (*supra*) has held as follows:

"12. The incident had occurred on 18.04.2018. It was concerning putting up of buntings and their removal on account of being declaration of elections to the Legislative Assembly of Karnataka State. The buntings were put up on the occasion of arrival of Sri Amit Shah, for an election rally. The Code of Conduct was also in place having been issued by the Election Commission and the Election Commission of India has been issuing orders from time whenever elections take place. The order dated 7th October, 2008 is followed even on 13th March, 2021 for General Elections. The order insofar as it is relevant for the purpose of this lis is extracted herein for the purpose of quick reference:

"DEFAACEMENT OF PUBLIC PLACES

4(a) No wall writing, pasting of posters/papers or defacement in any other form, or erecting/displaying of cutout, hoardings, banners, flags etc. shall be permitted on any Government premises (including civil structures therein). For this purpose a Government premise would include any Govt. office and the campus wherein the office building is situated.

(b) If the local law expressly permits or provides for writing of slogans, displaying posters, etc., or erecting cut-outs, hoardings, banners, political advertisement, etc., in any public place, (as against a Government premise) on payment or otherwise, this may be allowed strictly in accordance with the relevant provisions of the law and subject to Court orders, if any on this subject. It should be ensured that any such place is not

dominated/monopolized by any particular party(ies) or candidate(s). All parties and candidates should be provided equal opportunity in this regard.

(c) If there is a specifically earmarked place provided for displaying advertisements in a public place e.g. bill boards, hoardings etc. and if such space is already let out to any agency for further allocation to individual clients, the District Election Officer through the municipal authority concerned, if any, should ensure that all political parties and candidates get equitable opportunity to have access to such advertisement space for election related advertisements during the election period."

The defacement of property in terms of Election Commission would be in violation of Disfigurement Act as could be seen from the Annexure appended to the said order. Clause 10 of the order, reads as follows:

<i>Sl.No.</i>	<i>10.</i>
<i>Name of State/UT</i>	<i>Karnataka</i>
<i>Name of Act/Rule</i>	<i>The Karnataka Open Places (Prevention of Disfigurement) Act, 1981 as amended vide Act of 1983.</i>
<i>Extent of Applicability</i>	<i>It extends to Bangalore, Mysore, Hubli, Dharwar, Mangalore and Belgaum constituted or continued under the Karnataka Municipal Corporation Act, 1976, or under any other law on 5-05-1981 and come into force in the</i>

Municipalities, notified areas, sanitary Boards, constituted or continued under the Karnataka Municipalities act, 1964, or under any other law, or in any other local area, on such date as the State Govt. may by notification appoint."

(emphasis added)

The action of putting up buntings and their removal took place between 6 a.m. and 9 a.m., resulting in registration of complaint by Mr.Nisar Ahmed, an Official of the Municipality. The allegation was violation of Section 3 of the Disfigurement Act. Section 3 of the Disfigurement Act, 1981 reads as follows:

"3. Penalty for unauthorized disfigurement by advertisement. – *Whoever by himself or through another person affixes to, or erects, inscribes or exhibits on, any place open to public view any advertisement without the written permission of the local authority having jurisdiction over such area, shall be punished with imprisonment of either description for a term which may extend to six months or with fine which may extend to one thousand rupees, or with both:*

Provided that nothing in this section shall apply to any advertisement which, -

(i) is exhibited within the window of any building if the advertisement relates to the trade, profession or business carried on in that building; or

(ii) relates to the trade, profession or business carried on within the land or building upon or over which such advertisement is exhibited or to any sale

or letting of such land or building or any effects therein or to any sale, entertainment or meeting to be held on or upon or in the same; or

(iii) relates to the name of the land or building upon or over which the advertisement is exhibited, or to name of the owner or occupier of such land or building; or

(iv) relates to the business of a railway administration and is exhibited within any railway station or upon any wall or other property of a railway administration.

(v) is affixed to or exhibited on any ancient and historical monument declared to be of national importance under the Ancient Monuments and Archaeological Sites and Remains Act, 1958 (Central Act XXIV of 1958)."

The violation or contravention of the afore-quoted law forms the basis of the complaint registered at 9 a.m. by Sri Nisar Ahmed. The violations alleged in the said complaint which became an FIR in Crime No.223 of 2018, are in terms of Representation of Peoples Act, Disfigurement Act and Section 171H of the IPC. The relevant portion of the FIR reads as follows:

"2. ಕಾಯ್ದೆ ಮತ್ತು ಕಲಂಗಳು: REPRESENTATION OF PEOPLE ACT, 1951 & 1988 (U/S- 127A); KARNATKA OPEN PLACE DISFIGUREMENT ACT 1951 & 1981 (U/S- 3); IPC 1860 (U/S- 171 H)

3. (a) ಕೃತ್ಯ ನಡೆದ ದಿನ: Wednesday ದಿನಾಂಕ ದಿಂದ: 18/04/2018
ದಿನಾಂಕ ವರೆಗೆ: 18/04/2018

ವೇಳೆಯಿಂದ:06:00:00 ವೇಳೆಯವರೆಗೆ:06:10:00

(b) ತಾಣೆಯಲ್ಲಿ ವರ್ತಮಾನ ಸ್ಥಿತಿಗೊಳಿಸಿದ ದಿನಾಂಕ:18/04/2018 09:00:00

ಬರವಣಿಗೆಯಲ್ಲಿ / ಹೇಳಿಕೆ : Written

(c) ಪಿಯೂದುದಾರ / ಬಾತ್ಮೀದಾರ ತಡವಾಗಿ ವರದಿ ಮಾಡಿದಕ್ಕೆ
ಕಾರಣಗಳು: - -

(d) ಜನರಲ್ ಡೈರಿ ಉಲ್ಲೇಖ ಸಂಖ್ಯೆ ಮತ್ತು ಸಮಯ: 2, 09:00:00

4(a) ಕೃತ್ಯ ನಡೆದ ಸ್ಥಳ: J C Circle, Hosakote Town,
Bengaluru Dist, Karnataka.

(b) ಪೊಲೀಸ್ ಠಾಣೆಯಿಂದ
ಇರುವ ದಿಕ್ಕು ಮತ್ತು ದೂರ: Towards East 1

(c) ಗ್ರಾಮ: HOSAKOTE
ಗಸ್ತಿನ ಹೆಸರು: BEAT NO.1

(d) ಸ್ಥಳವು ಬೇರೆ ಪೊಲೀಸ್ ಠಾಣೆ ವ್ಯಾಪ್ತಿಗೆ ಬರುವಂತಹದ್ದು ಆದರೆ ಆ
ಪೊಲೀಸ್ ಠಾಣೆಯ ಹೆಸರು: ಜಿಲ್ಲೆ:

5. ಪಿಯೂದುದಾರ / ಬಾತ್ಮೀದಾರ:

(a) ಹೆಸರು : **Nisar Ahmed**
ತಂದೆ / ಗಂಡನ ಹೆಸರು: **Nazeer Ahmed**

(b) ವಯಸ್ಸು : 55 (c) ವೃತ್ತಿ : **Govt. official**
gazetted

The accused were workers of BJP. The allegations in the
FIR as contained in Clause 10 read as follows:

"10. ಪ್ರಥಮ ವರ್ತಮಾನ ವರದಿಯ ವಿವರಗಳು

ದಿನಾಂಕ 18.04.2018 ರಂದು ಬೆಳಿಗ್ಗೆ 09.00 ಗಂಟೆಗೆ ನಿಸಾರ್ ಅಹಮದ್, 55 ವರ್ಷ, ಪೌರಾಯುಕ್ತರು, ಹೊಸಕೋಟೆ ನಗರ ಸಭೆ ಹಾಗೂ ಫ್ಲೆಯಿಂಗ್ ಸ್ವಾವಡ್ ತಂಡದ ಮುಖ್ಯಸ್ಥರು, ಹೊಸಕೋಟೆ ವಿಧಾನ ಸಭಾ ಕ್ಷೇತ್ರ ಸಂಖ್ಯೆ 178, ಮೊಬೈಲ್ ನಂ.9481342786 ರವರು ಠಾಣೆಗೆ ಹಾಜರಾಗಿ ನೀಡಿದ ದೂರಿನ ಸಾರಾಂಶವೆಂದರೆ ಹೊಸಕೋಟೆ ವಿಧಾನ ಸಭಾ ಕ್ಷೇತ್ರ ಸಂಖ್ಯೆ 178 ಗೆ ಹಾಗೂ ಫ್ಲೆಯಿಂಗ್ ಸ್ವಾವಡ್ ತಂಡದ ಮುಖ್ಯಸ್ಥರಾಗಿ ಕರ್ತವ್ಯಕ್ಕೆ ನೇಮಕ ಮಾಡಿದ್ದು, ದಿನಾಂಕ 18.04.2018 ರಂದು ಬೆಳಿಗ್ಗೆ ನಾನು ಹೊಸಕೋಟೆ ಟೌನ್ ನಲ್ಲಿ ರೌಂಡ್ ಮಾಡಿಕೊಂಡು ಜಿ.ಸಿ.ಸರ್ಕಲಿಗೆ ಬಂದಾಗ ಜಿ.ಸಿ.ಸರ್ಕಲ್‌ನಲ್ಲಿ ಬಿಜೆಪಿ ಪಕ್ಷದ ಬಂಟಿಂಗ್‌ಗಳನ್ನು ಹಾಕಿದ್ದು ಬಂಟಿಂಗ್‌ಗಳನ್ನು ಹಾಕಲು ಯಾವುದೇ ಅನುಮತಿ ಪಡೆದಿರುವುದಿಲ್ಲ, ಆದ್ದರಿಂದ

ಅನುಮತಿ ಪಡೆಯದೆ ಬಂಟಿಂಗ್‌ಗಳನ್ನು ಹಾಕಿರುವವರ ವಿರುದ್ಧ ಕಾನೂನು ರೀತ್ಯಾ ಕ್ರಮ ಜರುಗಿಸಲು ಕೋರುತ್ತೇನೆ ಇತ್ಯಾದಿಯಾಗಿ ನೀಡಿದ ದೂರಿನ ಮೇರೆಗೆ.”

(emphasis added)

Immediately thereafter, a second complaint came to be registered against the petitioner and several others alleging the offences punishable under Sections 504, 332 and 353 of the IPC, which came to be registered as Crime No.224 of 2018. The second FIR reads as follows:

"1. ಜಿಲ್ಲೆ: **Bengaluru Dist.** ವೃತ್ತ/ಉಪವಿಭಾಗ: **Hosakote Circle**
ಪೊಲೀಸ್ ಠಾಣೆ: **Hosakote PS**
ಅಪರಾಧ ಸಂಖ್ಯೆ : 0224/2018 ಪ್ರ.ವ.ವ.ದಿನಾಂಕ : 18/04/2018

2. ಕಾಯ್ದೆ ಮತ್ತು ಕಲಂಗಳು: **IPC 1860 (U/S- 504, 332, 353)**

3. (a) ಕೃತ್ಯ ನಡೆದ ದಿನ: **Wednesday** ದಿನಾಂಕ ದಿಂದ: 18/04/2018
ದಿನಾಂಕ ವರೆಗೆ: 18/04/2018

ವೇಳೆಯಿಂದ:07:45:00ವೇಳೆಯವರೆಗೆ:07:50:00

(b) ಠಾಣೆಯಲ್ಲಿ ವರ್ತಮಾನ ಸ್ವೀಕರಿಸಿದ ದಿನಾಂಕ:18/04/2018
09:15:00 ಬರವಣಿಗೆಯಲ್ಲಿ / ಹೇಳಿಕೆ : **Written**

(c) ಪಿಯೂದುದಾರ / ಬಾತ್ಮೀದಾರ ತಡವಾಗಿ ವರದಿ ಮಾಡಿದಕ್ಕೆ ಕಾರಣಗಳು: - -

(d) ಜನರಲ್ ಡೈರಿ ಉಲ್ಲೇಖ ಸಂಖ್ಯೆ ಮತ್ತು ಸಮಯ: 3, 09:15:00

4(a) ಕೃತ್ಯ ನಡೆದ ಸ್ಥಳ: **J C Circle, Hosakote Town, Bengaluru Dist, Karnataka.**

(b) ಪೊಲೀಸ್ ಠಾಣೆಯಿಂದ ಇರುವ ದಿಕ್ಕು ಮತ್ತು ದೂರ: **Towards East 1 km**

(c) ಗ್ರಾಮ: **HOSAKOTE TOWN** ಗಸ್ತಿನ ಹೆಸರು: **BEAT NO.1**

(d) ಸ್ಥಳವು ಬೇರೆ ಪೊಲೀಸ್ ಠಾಣೆ ವ್ಯಾಪ್ತಿಗೆ ಬರುವಂತಹದ್ದು ಆದರೆ ಆ ಪೊಲೀಸ್ ಠಾಣೆಯ ಹೆಸರು: ಜಿಲ್ಲೆ:

5. ಪಿಯೂದುದಾರ / ಬಾತ್ಮೀದಾರ:

(a) ಹೆಸರು : **Nisar Ahmed**

ತಂದೆ / ಗಂಡನ ಹೆಸರು: **Nazeer Ahmed**

(emphasis added)

The allegation at clause 10 in the second FIR reads as follows:

"10. ದಿನಾಂಕ 18.04.2018 ರಂದು ಬೆಳಿಗ್ಗೆ 9.15 ಗಂಟೆಗೆ ನಿಸಾರ್ ಅಹಮ್ಮದ್ ಬಿನ್ ನಜೀರ್ ಅಹ್ಮದ್, 55 ವರ್ಷ, ಪೌರಾಯುಕ್ತರು, ಹೊಸಕೋಟೆ ನಗರ ಸಭೆ ಹಾಗೂ ಪ್ಲೇಯಿಂಗ್ ಸ್ಕಾವಡ್ ತಂಡದ ಮುಖ್ಯಸ್ಥರು, ಹೊಸಕೋಟೆ ವಿಧಾನ ಸಭಾ ಕ್ಷೇತ್ರ ಸಂಖ್ಯೆ 178, ಮೊಬೈಲ್ ನಂ.9481342786 ರವರು ತಾಣೆಗೆ ಹಾಜರಾಗಿ ನೀಡಿದ ದೂರಿನ ಸಾರಾಂಶವೆಂದರೆ ಹೊಸಕೋಟೆ ವಿಧಾನ ಸಭಾ ಕ್ಷೇತ್ರ ಸಂಖ್ಯೆ 178 ಗೆ ಪ್ಲೇಯಿಂಗ್ ಸ್ಕಾವಡ್ ತಂಡದ ಮುಖ್ಯಸ್ಥರಾಗಿ ದುನಾವಣಾಧಿಕಾರಿಯವರು ನೇಮಕ ಮಾಡಿದ್ದು ಅದರಂತೆ ನಾನು ದಿನಾಂಕ 18.04.2018 ರಂದು ಬೆಳಿಗ್ಗೆ ಹೊಸಕೋಟೆ ಟೌನ್‌ನಲ್ಲಿ ರೌಂಡ್‌ನಲ್ಲಿದ್ದಾಗ ಜೆ.ಸಿ.ಸರ್ಕಲಿನಲ್ಲಿ ದಿನಾಂಕ 18.04.2018 ರಂದು ಬಿಜೆಪಿ ಪಕ್ಷದ ರಾಷ್ಟ್ರೀಯ ಅಧ್ಯಕ್ಷರಾದ ಶ್ರೀ ಅಮಿತ್ ಷಾ ರವರು ಹೊಸಕೋಟೆಗೆ ಬರುವ ಕಾರ್ಯಕ್ರಮದ ಅಂಗವಾಗಿ ಬಿಜೆಪಿ ಪಕ್ಷದ ಬಂಟಿಂಗ್‌ಗಳನ್ನು ಹಾಕಿದ್ದು, ಬಂಟಿಂಗ್‌ಗಳನ್ನು ಹಾಕಲು ಅನುಮತಿ ಪಡೆದಿರುವುದಿಲ್ಲ, ಅನಧಿಕೃತವಾಗಿ ಹಾಕಿದ್ದ ಬಂಟಿಂಗ್‌ಗಳನ್ನು ತೆರವುಗೊಳಿಸುವಂತೆ ಹೊಸಕೋಟೆ ನಗರ ಸಭೆ ಆರೋಗ್ಯ ನಿರೀಕ್ಷಕರಾದ ನುಸರತ್ ಬಾನು ರವರಿಗೆ ತಿಳಿಸಿದ್ದು ಅದರಂತೆ ಅವರು ಸಿಬ್ಬಂದಿಗಳಾದ ಎ.ನಾಗರಾಜು, ಚನ್ನದೇಶವ, ರಮೇಶ್, ಅಶೋಕ್, ಹಾಗೂ ಇನ್ನಿತರ ಪೌರಕಾರ್ಮಿಕರೊಂದಿಗೆ ಇದೆ ದಿನ ಬೆಳಿಗ್ಗೆ ಸುಮಾರು 6.45 ಗಂಟೆ ಸಮಯದಲ್ಲಿ ಜೆ.ಸಿ.ಸರ್ಕಲಿಗೆ ಹೋಗಿ ಬಂಟಿಂಗ್‌ಗಳನ್ನು ತೆರವುಗೊಳಿಸುತ್ತಿದ್ದಾಗ ಅಲ್ಲಿಗೆ ಬಂದ ಬಿಜೆಪಿ ಪಕ್ಷದ ಮುಖಂಡರಾದ ಬಿ.ವಿ.ಬೈರೇಗೌಡ, ಕೇಶವಮೂರ್ತಿ, ಸುಬ್ಬರಾಜು ಹಾಗೂ ಇನ್ನಿತರರು ಅಡ್ಡಪಡಿಸಿರುತ್ತಾರೆ ತೆರವುಗೊಳಿಸಲು ಬಿಡುತ್ತಿಲ್ಲ ಎಂದು ನುಸರತ್ ಬಾನು ರವರು ನನಗೆ ಫೋನ್ ಮಾಡಿ ತಿಳಿಸಿದ್ದರು, ನಾನು ಇದೇ ದಿನ ಬೆಳಿಗ್ಗೆ 7:45 ಗಂಟೆಗೆ ಜೆ ಸಿ ಸರ್ಕಲಿಗೆ ಹೋಗಿ ನಗರಸಭೆ ಸಿಬ್ಬಂದಿಯೊಂದಿಗೆ ಅನಧಿಕೃತವಾಗಿ ಹಾಕಿದ್ದ ಬಂಟಿಂಗ್‌ಗಳನ್ನು ತೆರವುಗೊಳಿಸಲು ಹೋದಾಗ ಬಿಜೆಪಿ ಪಕ್ಷದ ಮುಖಂಡರುಗಳು ಆದ ಬಿ.ವಿ.ಬೈರೇಗೌಡ, ಸುಬ್ಬರಾಜು, ಕೇಶವಮೂರ್ತಿ ಹಾಗೂ ಇನ್ನಿತರು ಸೇರಿ ಬಾಯಿಗೆ ಬಂದಂತೆ ಅವಾಚ್ಯ ಶಬ್ದಗಳಿಂದ ಬೈದು ಬೈರೇಗೌಡರ ಜೊತೆಯಲ್ಲಿದ್ದ ಕಮ್‌ವಾರಿಪೇಟೆ ವಾಸಿ ಅಶೋಕ ರವರು ಕೈಗಳಿಂದ ನನಗೆ ಹೊಡೆದು ಹಲ್ಲೆ ಮಾಡಿರುತ್ತಾರೆ, ಚುನಾವಣಾ ಕರ್ತವ್ಯಕ್ಕೆ ಹಾಗೂ ಸರ್ಕಾರಿ ಕರ್ತವ್ಯಕ್ಕೆ ಅಡ್ಡಿಪಡಿಸಿರುವ ಮೇಲ್ಕಂಡವರ ವಿರುದ್ಧ ಕಾನೂನು ರೀತಿ ಕ್ರಮ ಜರುಗಿಸಲು ಕೋರುತ್ತೇನೆ ಎಂದು ಇತ್ಯಾದಿಯಾಗಿ ನೀಡಿದ ದೂರಿನ ಮೇರೆಗೆ."

If both the FIR in Crime No.223 of 2018 and FIR in Crime No.224 of 2018 are read in juxtaposition, what would unmistakably emerge is that, both the complaints are by the very same complainant, which pertain to the same incident and same time and date of incident. Once having registered a complaint on a particular premise of an incident, it was not open to the complainant to have registered another complaint on the very same incident regarding what happened during the very same period. The complainant cannot be permitted to improve on the earlier complaint and as an afterthought bring in other

offences in the second complaint becoming a second FIR on sameness. It would amount to permitting multiple FIRs' on the very same - incident, time of the incident, date of the incident and by the very same complainant. It would be hit by the doctrine of sameness as held by the Apex Court in the afore-extracted judgments. Therefore, insofar as Crime No.224 of 2018 is concerned, the criminal trial cannot be permitted to continue as it would fall foul of the cardinal principle of violation of fundamental rights of a citizen and the law laid down by the Apex Court, as aforesaid.

*13. A counter complaint is always permissible on the same incident as there can be complaints and two FIRs', if it is a case of complaint and counter complaint or a case of consequential complaint. These are not the facts in the case at hand. Therefore, without a shadow of doubt it would hit by '**doctrine of sameness**'."*

14. Insofar as the procedure followed by the learned Magistrate in referring the matter for investigation under Section 156(3) of the Cr.P.C., after having taken cognizance and referred the matter for inquiry under Section 202 of the Cr.P.C. is concerned there is a marked difference that the inquiry under Section 202 of the Cr.P.C. and reference under Section 156(3) of the Cr.P.C. is ordered. The Apex Court in the case of **KAILASH VIJAYVARGIYA** (*supra*) has elucidated the difference between the two. The Apex Court has held as follows:

“65. One would grant that the jurisdiction of the Court when asked to invoke power under Section 156(3) is wider as held in Priyanka Srivastava (supra), yet there are limits within which the Magistrate must act. When the Magistrate is satisfied that the allegations made disclose commission of a cognizable offence, he must stay his hands, direct registration of an FIR and leave it to the investigative agency to unearth the facts and ascertain the truth of the allegations. Magistrate in terms of the ratio in Lalita Kumari (supra) can for good reasons direct preliminary enquiry. We would now refer to the power of the Magistrate to take cognizance, postpone issue of process and follow the procedure under Section 202 of the Code.

Difference in the power of Police to register and investigate an FIR under Section 154(1) read with 157 of the Code, and the Magistrate's direction to register an FIR under Section 156(3) of the Code. Power of the Magistrate to direct registration of an FIR under Section 156(3) in contrast with post-cognizance stage power under Section 202 of the Code.

66. The operandi for registration of information in a cognizable offence and eventual investigation is not limited to Police, and as observed above, sub-section (3) to Section 156, subject to legal stipulations, gives the ameliorating power to a Magistrate empowered under Section 190 to order an investigation in a cognizable offence. Two different powers vested with two distinct authorities, namely the Police and the Magistrate, who discharge distinct functions and roles under the Code as indicated above are not entirely imbricating.

67. The power of Magistrate to direct investigation falls under two limbs of the Code : one is pre-cognizance stage under Section 156(3), and another on cognizance under Chapter XIV ('Conditions Requisite for Initiation of Proceedings'; Sections 190-199) read with Chapter XV ('Complaints to Magistrates'; Sections 200-210). These two

powers are different and there also lies a procedural distinction between the two.

68. *A three Judge Bench decision of this Court in Ramdev Food Products Private Limited (supra) had examined the distinction between powers of the Magistrate to direct registration of an FIR under Section 156(3) and power of the Magistrate to proceed under Section 202 of the Code. It was observed that the power under the former Section is to be exercised, on receiving a complaint or a Police report or information from any person other than the Police officer or upon his own knowledge, before he takes cognizance under Section 190. Once the Magistrate takes cognizance, the Magistrate has discretion to take recourse to his powers under Section 202, which provides for postponement of the issue of process and inquire into the case himself or direct investigation to be made by a Police officer or by such other person as he thinks fit for the purpose of deciding whether or not there are sufficient grounds for proceedings. The proviso to Section 202 states that no direction for investigation shall be made where a complaint has not been made by a Court, unless the complainant and the witnesses present (if any) are examined on oath under Section 200. When it appears to the Magistrate that the offence complained of is triable exclusively by the Court of Sessions, he shall call upon the complainant to produce all his witnesses and examine them on oath. However, in such cases, the Magistrate cannot issue direction for investigation of an offence. Thus, the Magistrate has the power, when a written complaint is made, to issue direction under Section 156(3), but this power is to be exercised before the Magistrate takes cognizance of the offence under Section 190. However, in both cases, whether under Section 156(3) or under Section 202 of the Code, the person accused as the perpetrator, when the proceedings are pending before the Magistrate, remains unrepresented. Under Section 203, the Magistrate, after considering the statement of the complainant and witnesses (if any) on oath and the result of an inquiry (if any) under Section 202, can dismiss the complaint if he is of the opinion that there is no sufficient ground for proceeding and in every such case briefly record his reasons. If the Magistrate after taking cognizance of the*

offence, is of the opinion that there are sufficient grounds for proceeding he will issue the process to the accused for appearance as per the procedure and mode specified under Section 204 of the Code. Process to the accused under Section 204 falls under Chapter XVI of the Code and is issued post the cognizance and inquiry/investigation/evidence recorded in a private complaint in terms of Section 202 of the Code."

(Emphasis supplied)

In the teeth of the aforesaid facts whether further proceedings could be permitted to be continued or otherwise is required to be answered and the answer is an unequivocal and emphatic '**no**', as if such proceedings are permitted to continue it would run foul of the judgment of the Apex Court in the case of **BHAJAN LAL** (*supra*), wherein it is held as follows:

"102. *In the backdrop of the interpretation of the various relevant provisions of the Code under Chapter XIV and of the principles of law enunciated by this Court in a series of decisions relating to the exercise of the extraordinary power under Article 226 or the inherent powers under Section 482 of the Code which we have extracted and reproduced above, we give the following categories of cases by way of illustration wherein such power could be exercised either to prevent abuse of the process of any court or otherwise to secure the ends of justice, though it may not be possible to lay down any precise, clearly defined and sufficiently channelised and inflexible guidelines or rigid formulae and to give an exhaustive list of myriad kinds of cases wherein such power should be exercised.*

- (1) **Where the allegations made in the first information report or the complaint, even if they are taken at their face value and accepted in their entirety do not prima facie constitute any offence or make out a case against the accused.**
- (2) *Where the allegations in the first information report and other materials, if any, accompanying the FIR do not disclose a cognizable offence, justifying an investigation by police officers under Section 156(1) of the Code except under an order of a Magistrate within the purview of Section 155(2) of the Code.*
- (3) *Where the uncontroverted allegations made in the FIR or complaint and the evidence collected in support of the same do not disclose the commission of any offence and make out a case against the accused.*
- (4) *Where, the allegations in the FIR do not constitute a cognizable offence but constitute only a non-cognizable offence, no investigation is permitted by a police officer without an order of a Magistrate as contemplated under Section 155(2) of the Code.*
- (5) **Where the allegations made in the FIR or complaint are so absurd and inherently improbable on the basis of which no prudent person can ever reach a just conclusion that there is sufficient ground for proceeding against the accused.**
- (6) *Where there is an express legal bar engrafted in any of the provisions of the Code or the concerned Act (under which a criminal proceeding is instituted) to the institution and continuance of the proceedings and/or where there is a specific provision in the Code or the concerned Act, providing efficacious redress for the grievance of the aggrieved party.*

- (7) *Where a criminal proceeding is manifestly attended with mala fide and/or where the proceeding is maliciously instituted with an ulterior motive for wreaking vengeance on the accused and with a view to spite him due to private and personal grudge.”*
(Emphasis supplied)

Therefore, finding no procedure or the procedure completely **topsy-turvy** in the cases at hand would mean that the entire proceedings need to be obliterated as glaring procedure aberrations noticed hereinabove cannot be countenanced and further proceedings cannot be permitted to continue by a fiat of this Court as they are all incurable illegalities cutting at the root of the matter and become an abuse of the process of the law.

15. For the aforesaid reasons, I pass the following:

ORDER

- (i) Criminal petitions are allowed and the proceedings in C.C.No.2319 of 2023 pending before the II Additional Civil Judge and Judicial Magistrate First Class, Davangere stand quashed *qua* the petitioners.
- (ii) It is made clear that the observations made in the course of the order are only for the purpose of consideration of the case of petitioners under Section

482 of Cr.P.C. and the same shall not bind or influence the proceedings against any other accused pending before the learned Magistrate or any other *fora*.

**Sd/-
JUDGE**

nvj
CT:SS